

TECHNISCHE INFORMATIONEN

- Balgen :** 0.5 Faltenbalg
- Federweg :** 2 mm
- Form :** Flach
- Höhe :** 28
- Horizontalkraft :** 60 N
- Kategorie :** Flach
- Lippendurchmesser :** 42
- Rohrinnendurchmesser :** G1/4
- Serie :** 90
- Sortiment :** Sauggreifer
- Vertikalkraft :** 30 N

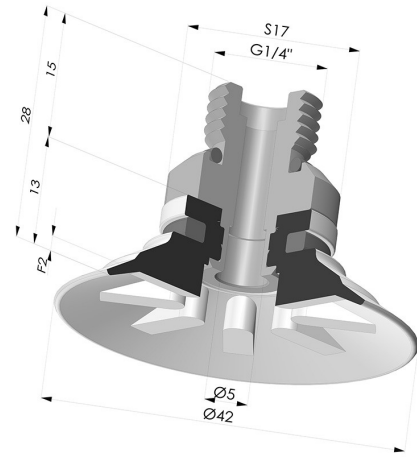

Varianten:



Variantenreferenz:
90 40SL 14D-2

- Farbe: Rot (Lebensmittels zertifikat)
- Materiale: Silikon
- Shore-Härte: SH60



Variantenreferenz:
90 40SLT 14D-2

- Farbe: Transluzent (Lebensmittels zertifikat)
- Materiale: Silikon
- Shore-Härte: SH60



Variantenreferenz:
90 40NI 14D-2

- Farbe: Schwarz
- Materiale: Nitril
- Shore-Härte: SH50



Variantenreferenz:
90 40PU 14D-2





- Farbe: Blau
- Materiale: PU
- Shore-Härte: SH60



Variantenreferenz:
90 40TPU 14D-2

- Farbe: Transluzent
- Materiale: Thermoplastisch
- Shore-Härte: SH70

Werkstoffleitfaden:

	Material	Code	Temperatur beständigkeit (°C)	Flexibilität	Abrieb festigkeit	UV/Witterungs beständigkeit	Ölbeständigkeit	Lebensmittel verträglichkeit	Migrationstest
	Silikon Rot (Lebensmittels zertifikat)	SL	-60/+250	✓✓✓	✗	✓✓✓	✗	FDA ☞☞	A, B, D2
	Silikon Transluzent (Lebensmittels zertifikat)	SLT	-60/+250	✓✓✓	✗	✓✓✓	✗	FDA ☞☞	✗
	Nitril Schwarz	NI	-10/+80	✓	✓	✗	✓✓	✗	✗
	Thermoplastisch Transluzent	TPU	-20/+80	✓	✓✓✓	✓	✓✓	✗	✗

